

## FL1

### COMPONENTES/COMPONENTS/COMPOSANTS

CODE	DESCRIPTION			UNITS
1	VIDRIO MÓVIL	MOBILE GLASS	PAROI MOBILE	1
2	BISAGRA	HINGE	CHARNIÈRE	2
3	TIRADOR	SHOOTER	TIREUR	1
4	CIERRE LATERAL	LATERAL CLOSING	FERMETURE LATÉRALE	1
5	JUNTA MAGNÉTICA	MAGNETIC JOINT	JOINT MAGNÉTIQUE	2
6	JUNTA BISAGRA	HINGE JOINT	JOINT DE LA CHARNIÈRE	1
7	GOMA INFERIOR	LOWER RUBBER	JOINT INFÉRIEUR	1
8	VIERTEAGUAS	RAIN GUARD	REJINGOT	1
9	REMATE VIERTEAGUAS	FINISH RAIN GUARD	COUVERCLE DU REJINGOT	2
10	TORNILLOS A PARED	WALL SCREW	VIS MURALE	3
11	TORNILLO INOX. (BISAGRA)	SCREW STAINLESS (HINGE)	VIS INOX. (CHARNIÈRE)	4
12	TACO	WALL PLUG	CHEVILLE	3
13	TACO (BISAGRA)	WALL PLUG (HINGE)	CHEVILLE (CHARNIÈRE)	4
14	ARANDELAS	WASHER	RONDELLE	3
15	EMBELLECEDORES	FINISH SCREW	CACHE-VIS	3
16	CALZO	CHOCK	CALE	1

### HERRAMIENTAS NECESARIAS/TOOLS NEEDED/OUTILS NÉCESSAIRES

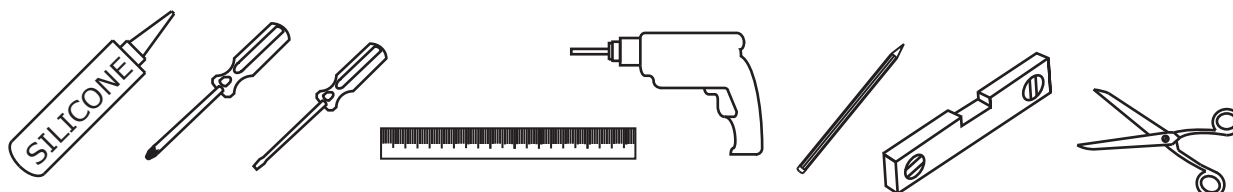

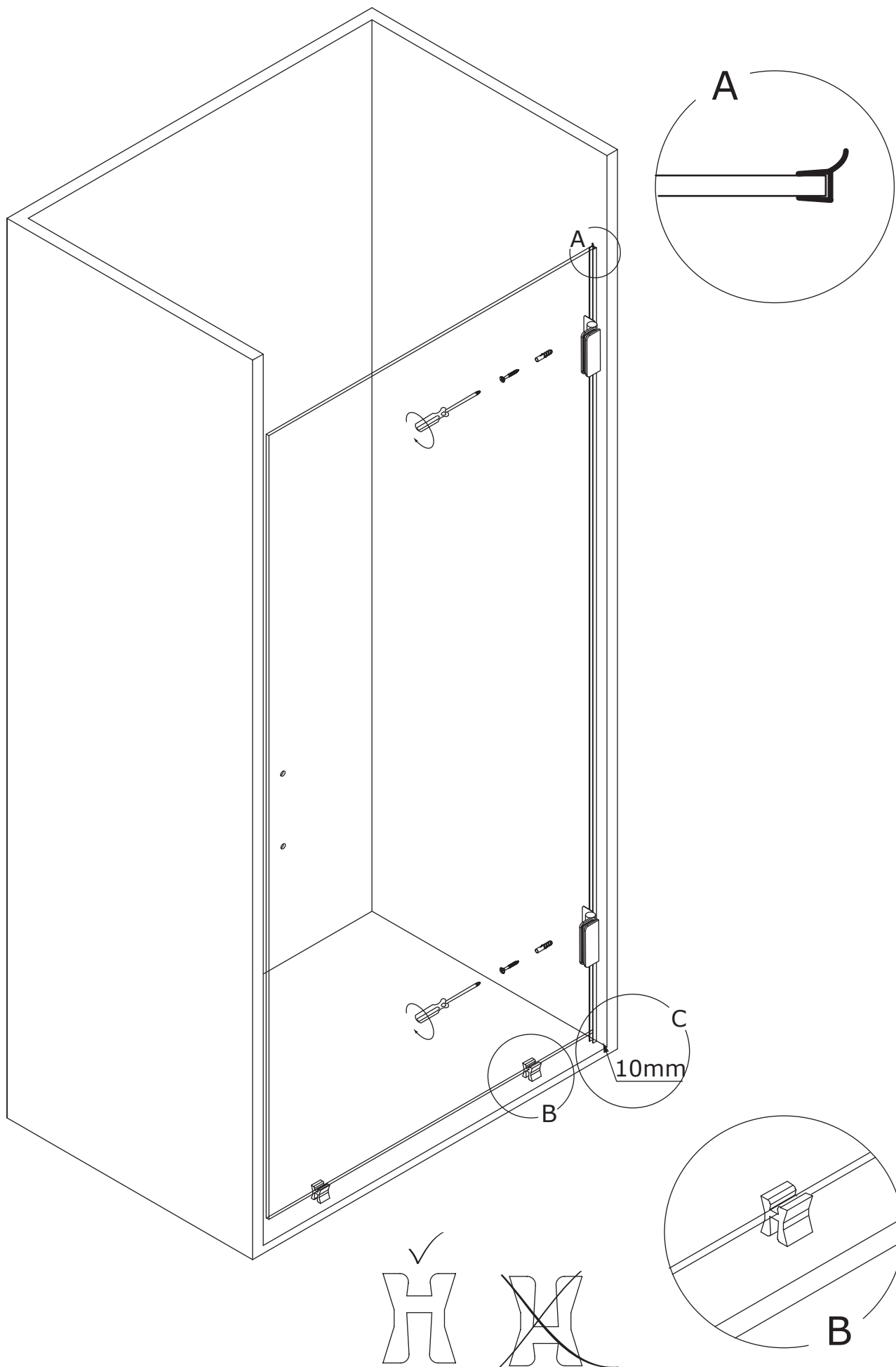

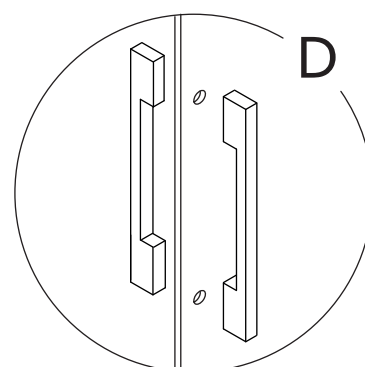
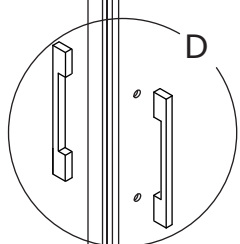
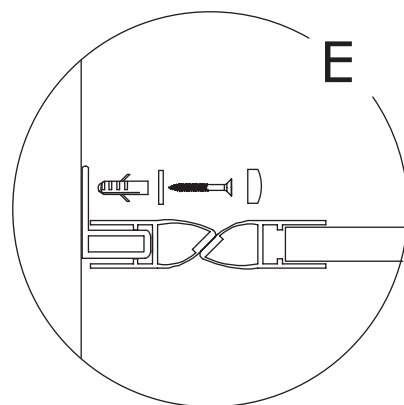
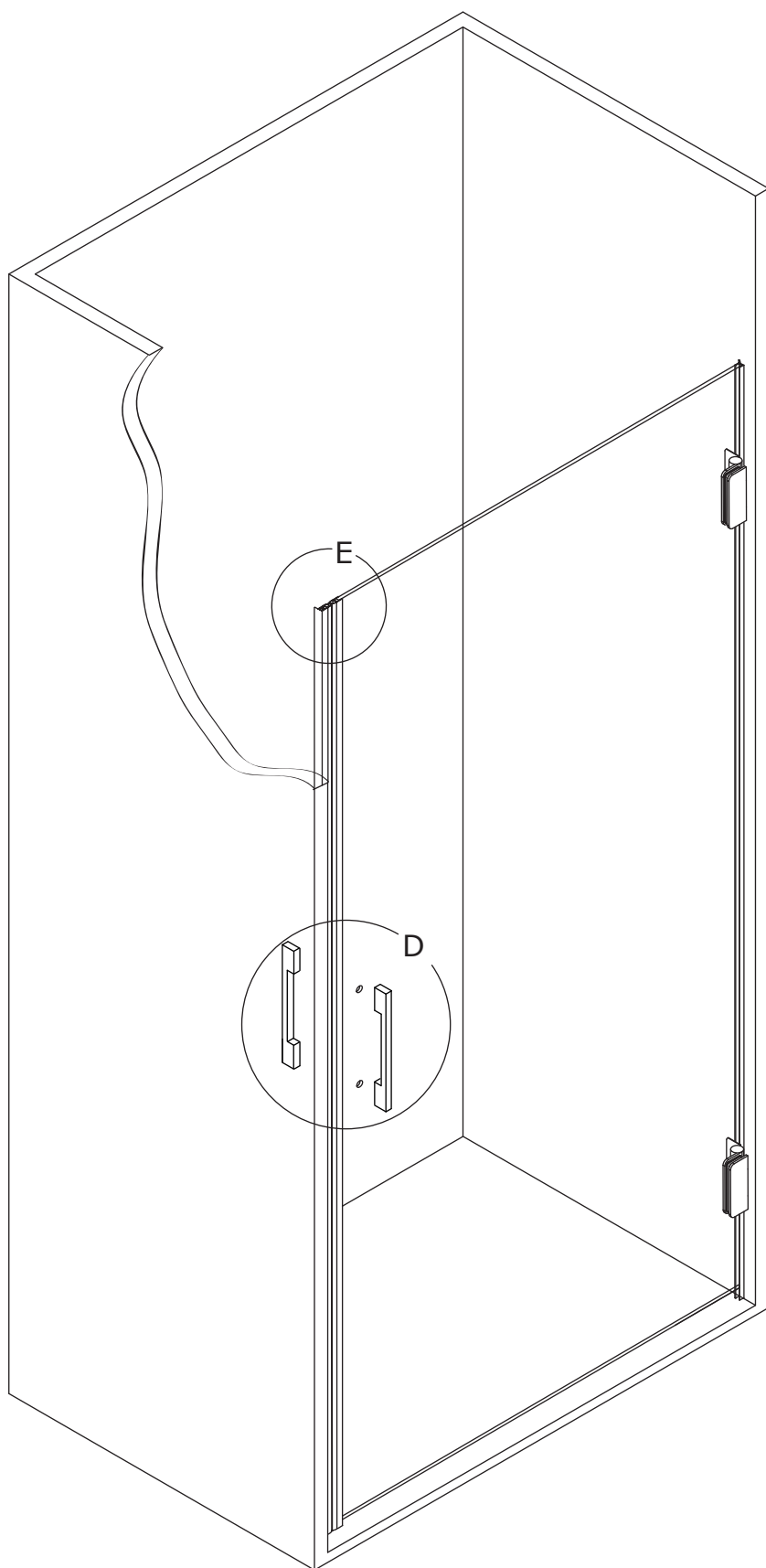

FL1

