

COMPONENTES/COMPONENTS/COMPOSANTS

CODE	DESCRIPTION			UNITS
1	VIDRIO MÓVIL	MOBILE GLASS	PAROI MOBILE	1
2	VIDRIO FIJO	FIXED GLASS	PAROI FIXE	1
3	BISAGRA	HINGE	CHARNIÈRE	2
4	TIRADOR	SHOOTER	TIREUR	1
5	BARRA DE REFUERZO	REINFORCEMENT BAR	BARRE DE RENFORCEMENT	1
6	PERFIL A PARED	WALL ATTACHMENT PROFILE	PROFILÉ À LA PAROI	2
7	JUNTA IMAN	MAGNETIC JOINT	JOINT BULLE	2
8	GOMA INFERIOR	LOWER RUBBER	JOINT MAGNETIQUE	1
9	VIERTEAGUAS	RAIN GUARD	REJINGOT	1
10	REMATE VIERTEAGUAS	FINISH RAIN GUARD	COUVERCLE DU REJINGOT	2
11	TAPA PERFIL A PARED	WALL ATTACHMENT PROFILE COVER	EMBOU PROFILÉ MURAL	1
12	TORNILLOS A PARED	WALL SCREW	VIS MURALE	3
13	AUTORROSCANTES	SELF-TAPPING SCREW	VIS AUTO-PERFORANTE	3
14	TACO	WALL PLUG	CHEVILLE	3
15	ARANDELAS	WASHER	RONDELLE	3
16	EMBELLECEDORES	FINISH SCREW	ENJOLIVEURS CACHE-VIS	3
17	CALZO	CHOCK	CALE	1
18	CIERRE LATERAL	LATERAL CLOSING	FERMETURE LATÉRALE	1

HERRAMIENTAS NECESARIAS/TOOLS NEEDED/OUTILS NÉCESSAIRES

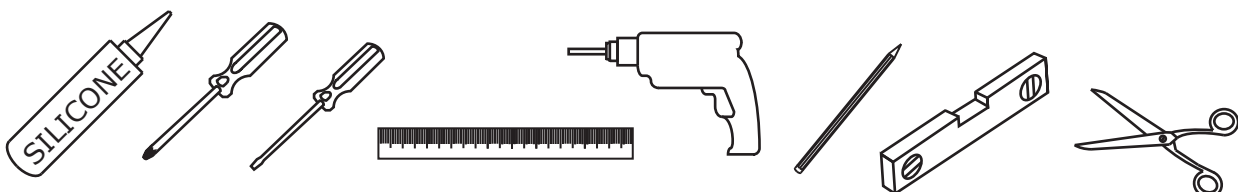

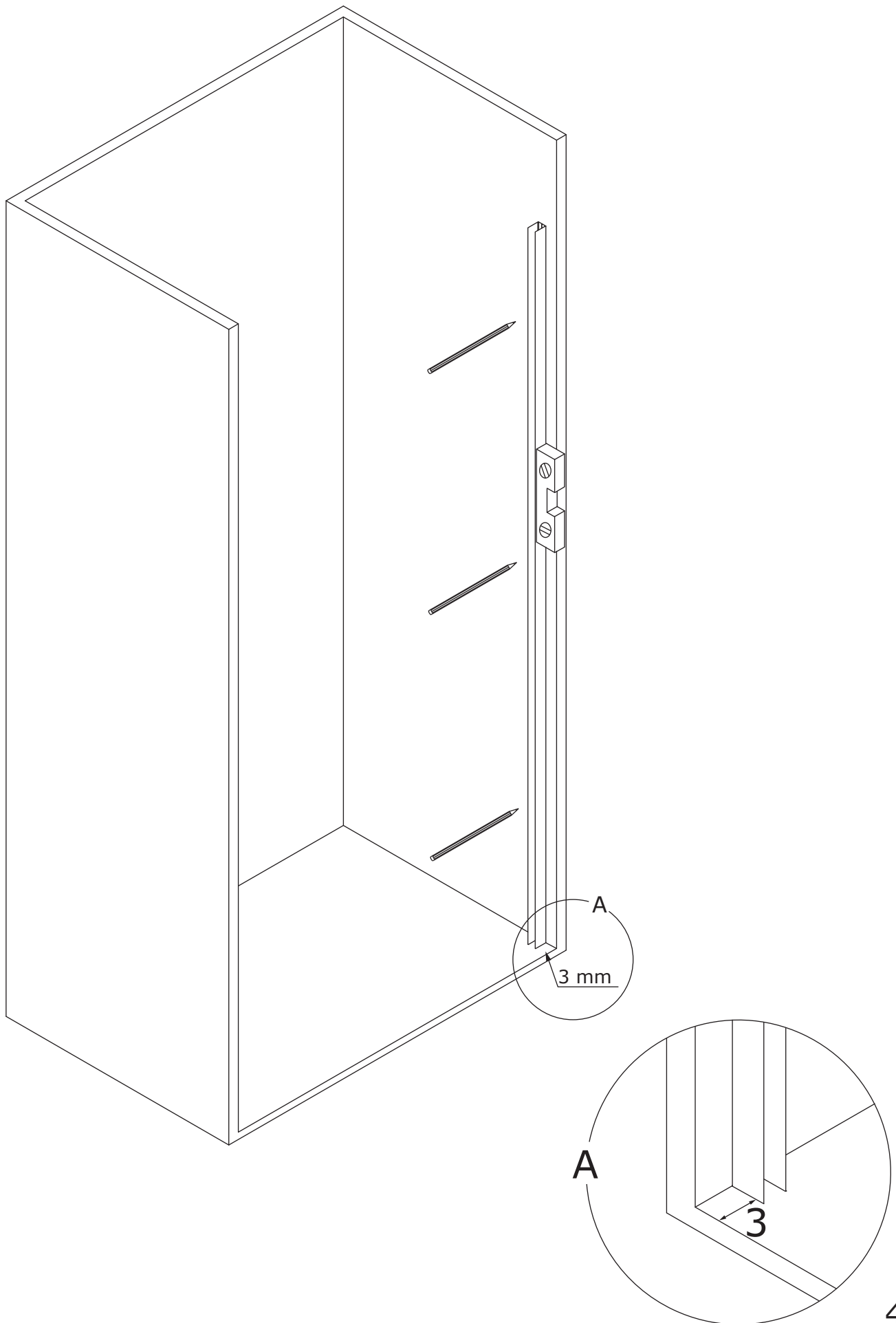

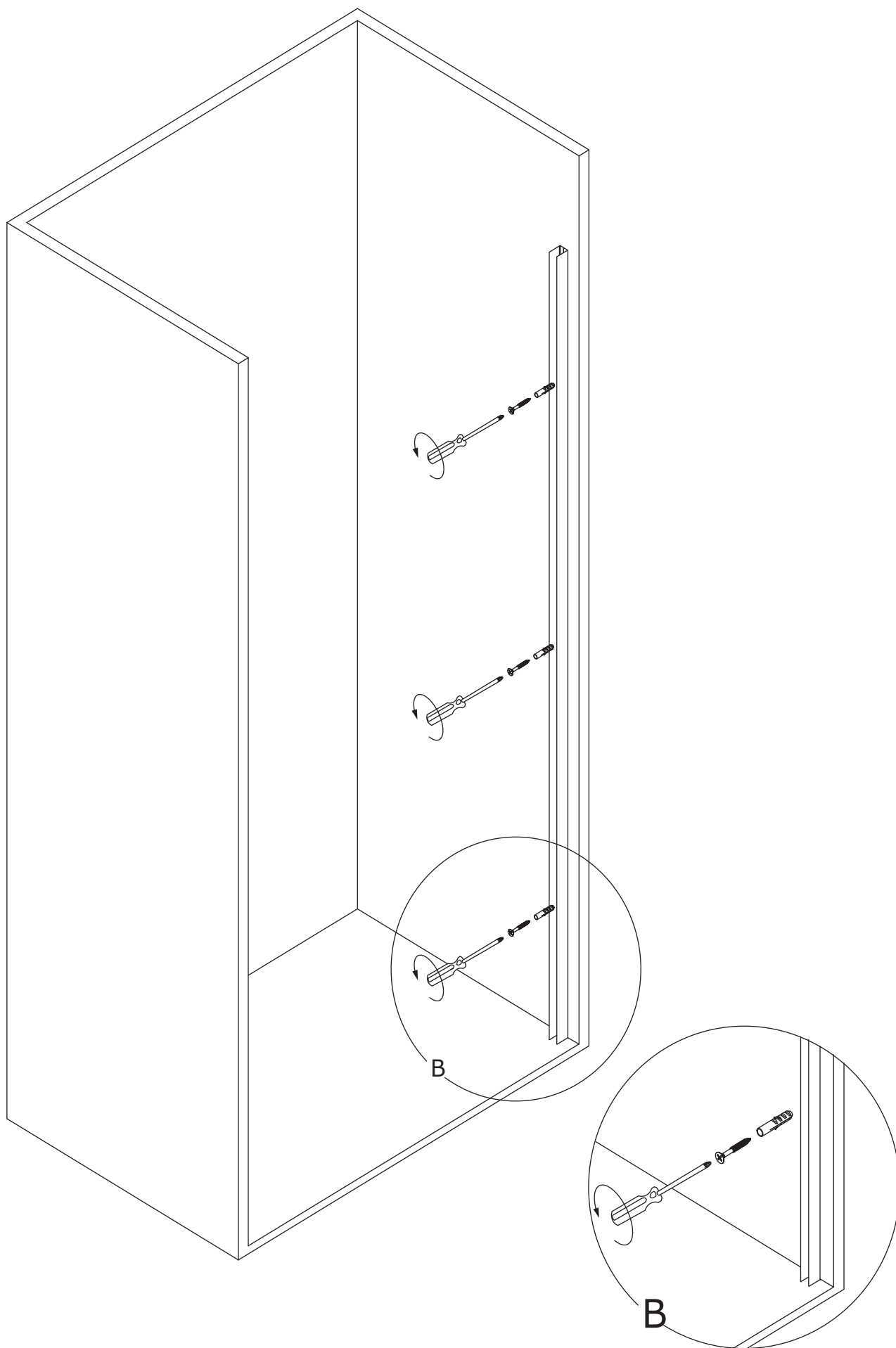

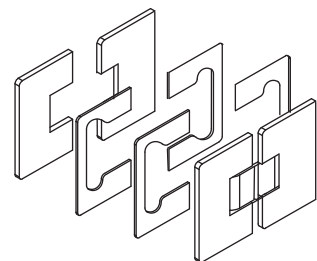
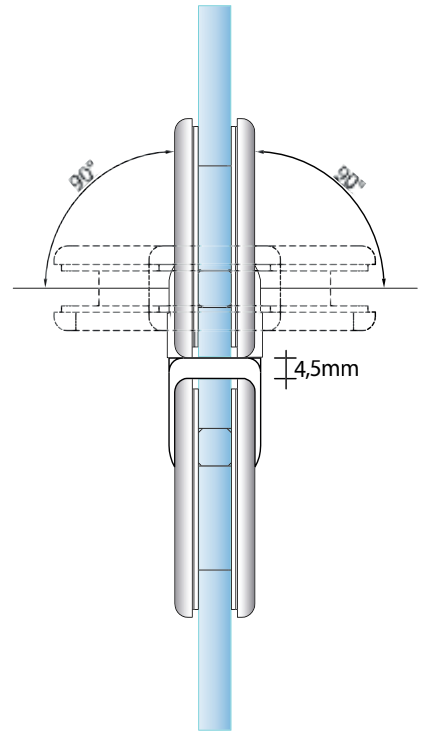
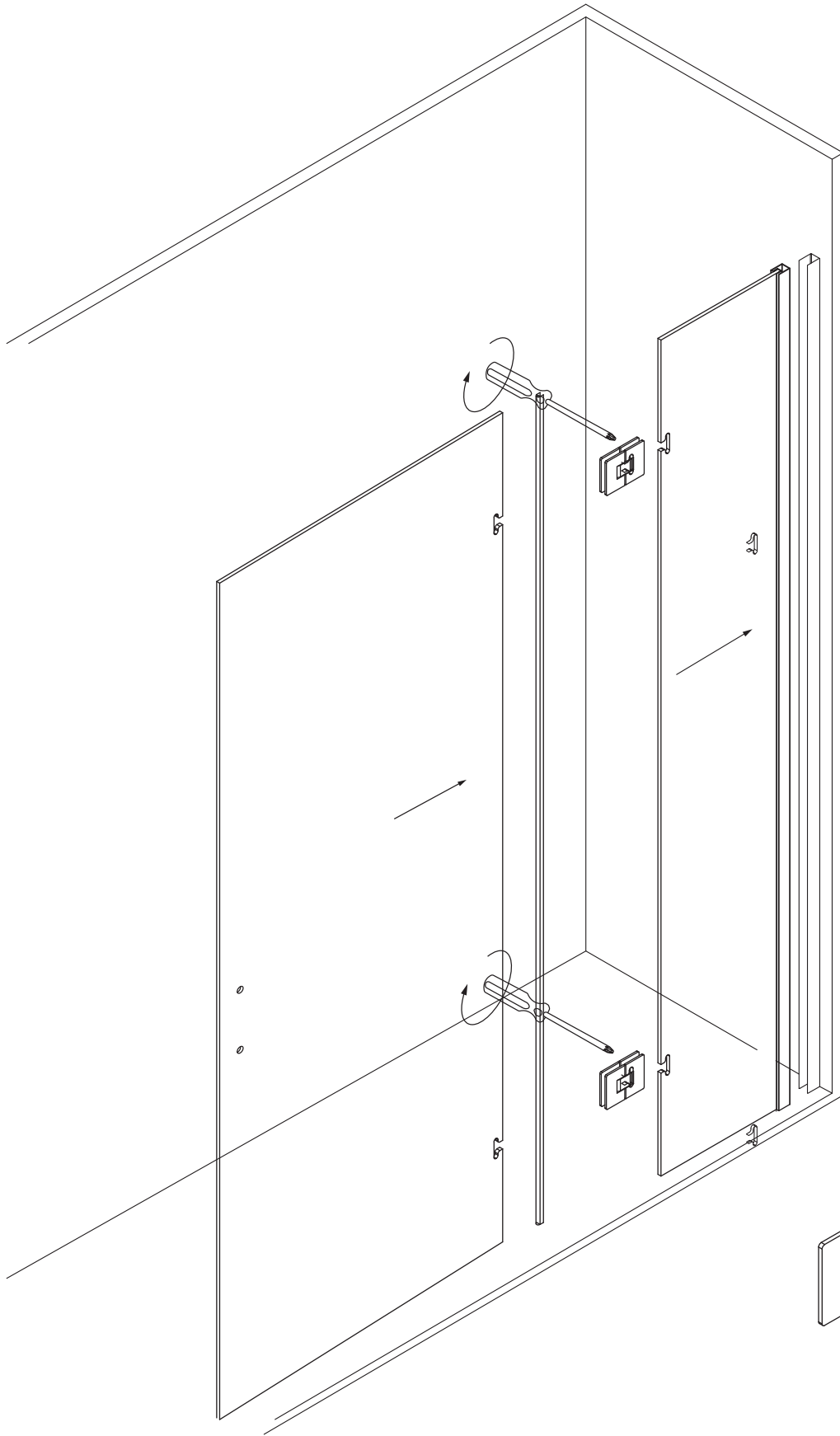

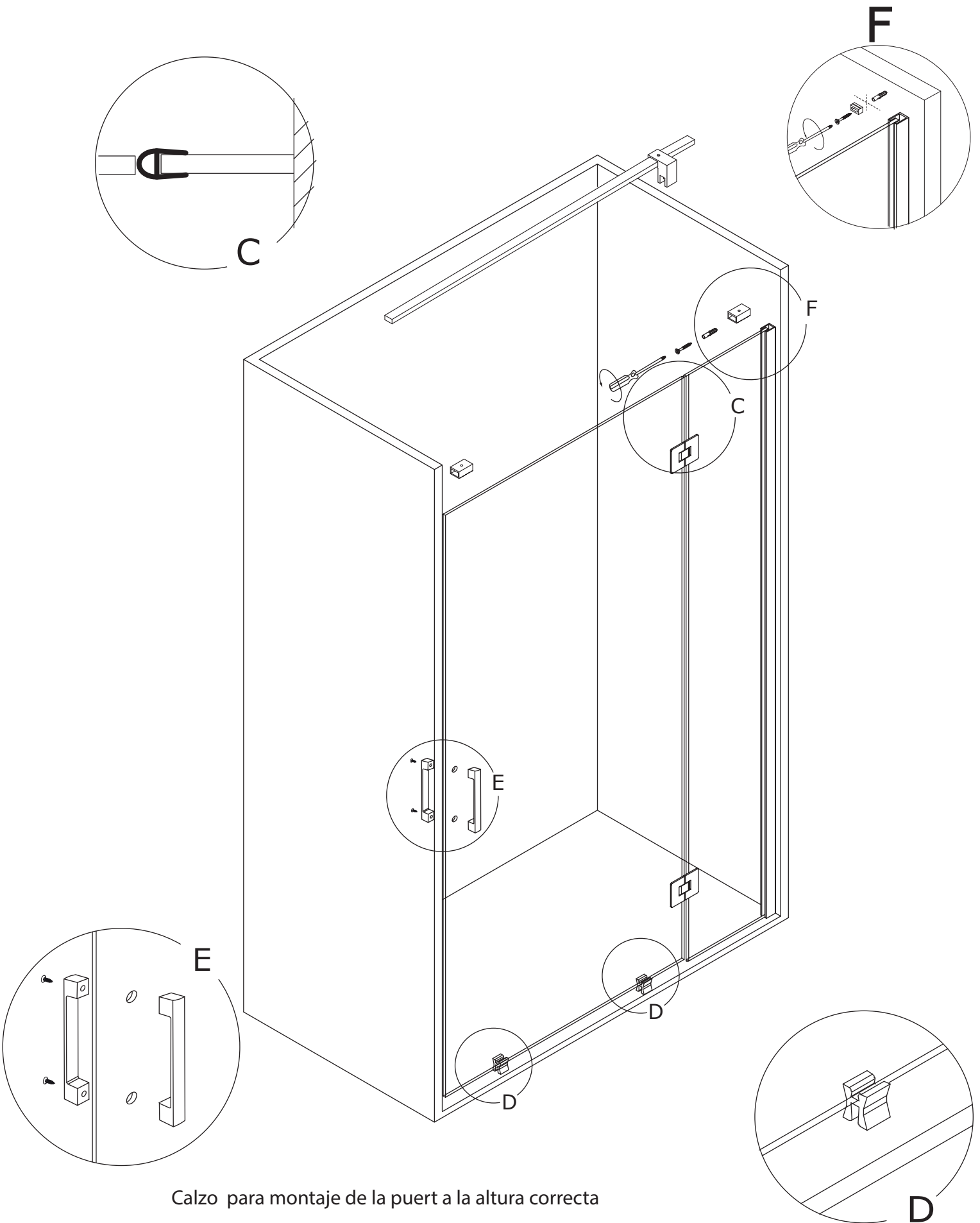

Calzo para montaje de la puerta a la altura correcta



Colocar por este lado Para vidrio de 8 mm

Colocar por este lado Para vidrio de 6 mm

D

7

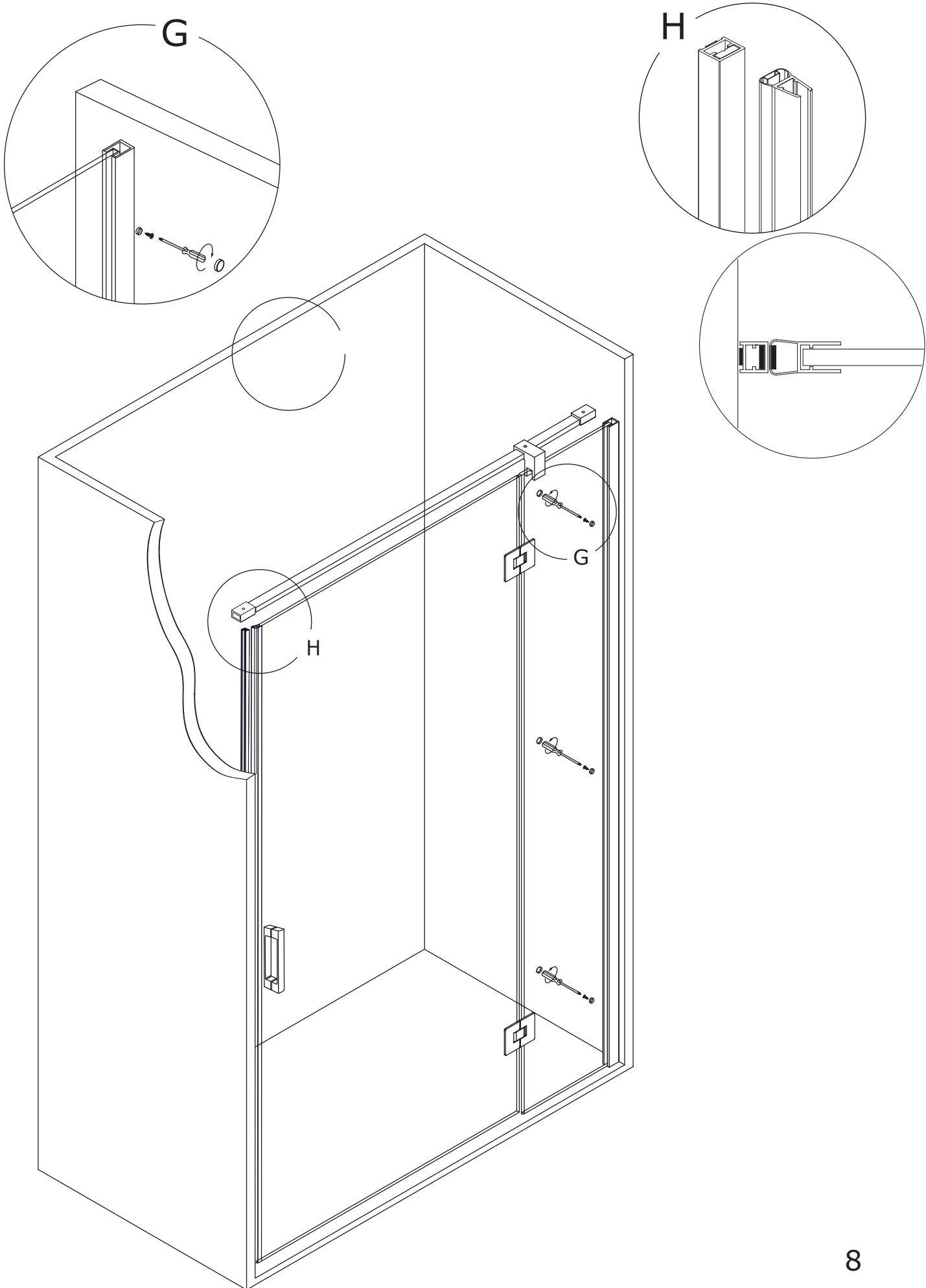

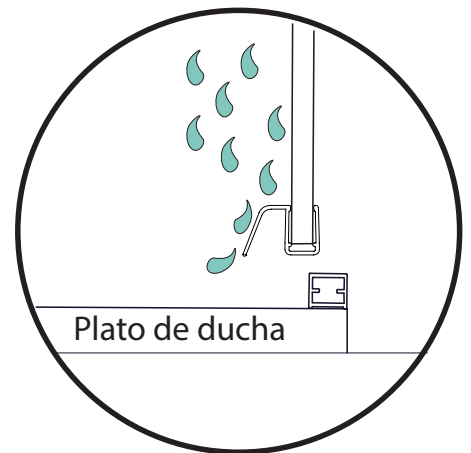
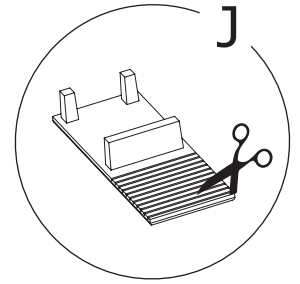
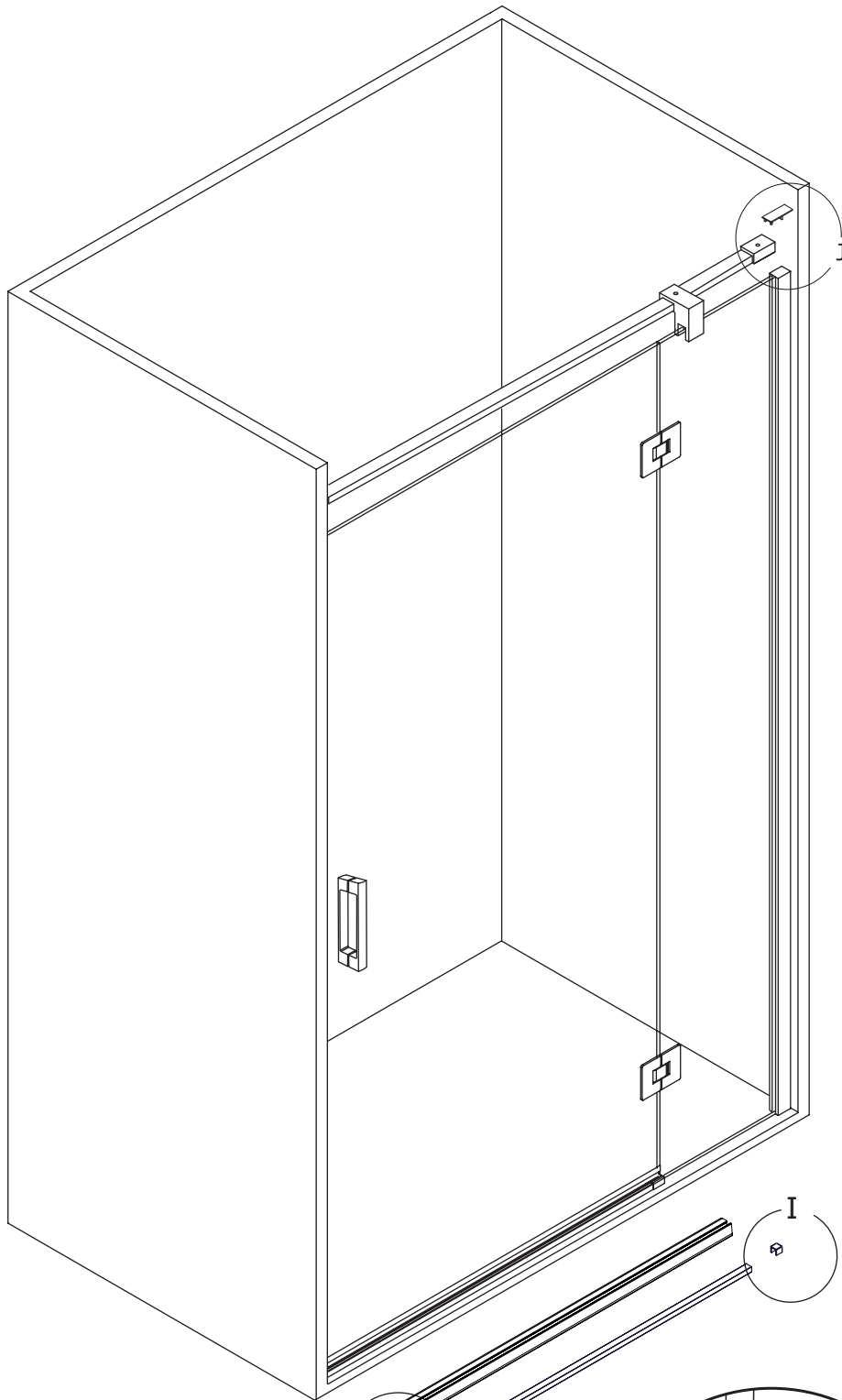

En el caso de que la junta roce demasiado con el vierteaguas, recortar la lengüeta para evitar que se pellizque

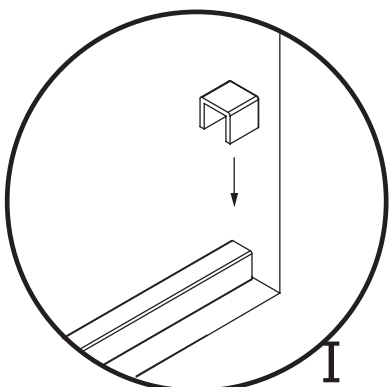
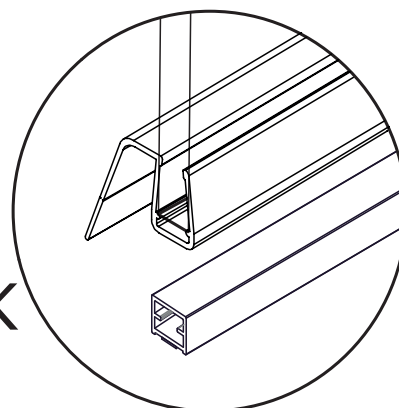
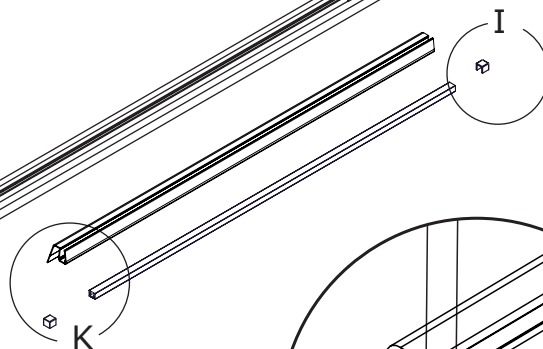
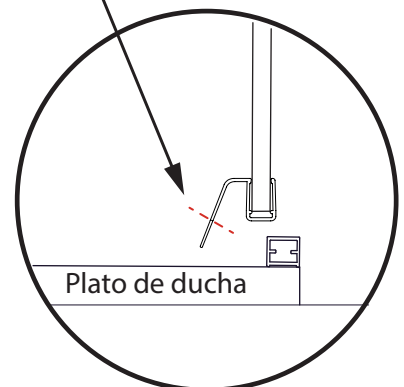
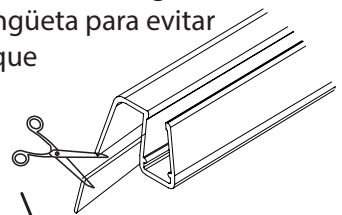

Eva - Eva Pro: E02C61/E02C62/E02C71/E02C72	
Espesor del vidrio Glass thickness	6-8-10mm
Màxima capacidat de pesu Maximum weight capacity	55KG
Anchura màxima de la puerta Maximum door width	840mm

1 Abertura

Destornillar los tornillos de la contraplaca. Después de haber removido la contraplaca, **no efectúen ningún movimiento de rotación de la bisagra.**

Unscrew the backplate screws. After removing the backplate **do not perform any rotation movement** to the hinge.

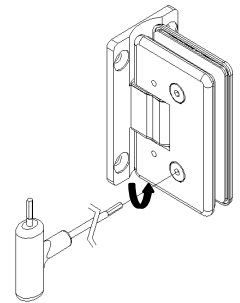

2 Guarniciones

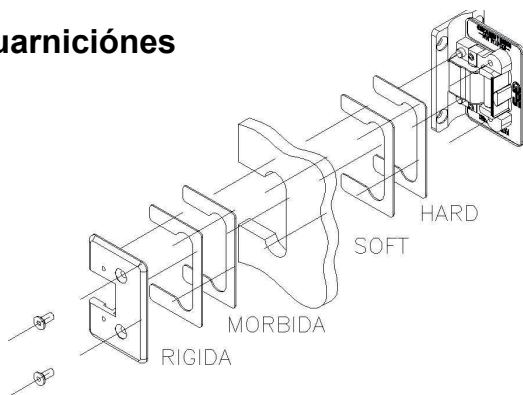

Espesor del vidrio Glass thickness	6mm	8mm	10mm
Guarnición rígida Hard gasket	N°2+2	N°2	N°0
Guarnición blanda Soft gasket	N°2	N°2	N°2

Insertar la bisagra en el vidrio como indicado en el esquema sobrestante, respetando la cantidad y la secuencia de las guarniciones. (Si el espesor del vidrio es inferior del nominal, insertar la guarnición blanda adicional suministrada en la parte externa de la bisagra para asegurar un buen agarre). Se recomienda montar ante todo la bisagra en la puerta y después en la pared

Install the hinge in the glass according to the drawing above. Pay attention to the number and sequence of the gaskets. (In case of glass thickness is less than nominal value, add in the external side, the extra soft gasket supplied to ensure a good grip of the hinge). Advice: first install the hinge on the door then on the

3 Cierre

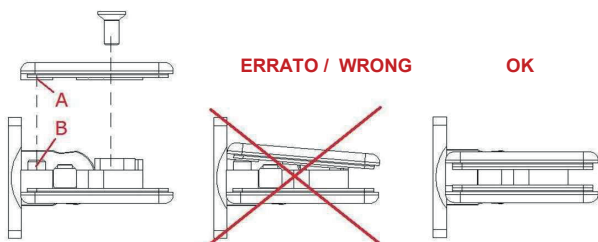

Reponer la contraplaca precedentemente removida. **Ponerse un cuidado especial** de que la placa, a través de los agujeros A sean perfectamente acoplados con los pernos B. La situación en la imagen cruzada con X nunca debe presentarse, ya que eso podría implicar la posible ruptura del mecanismo. Una vez que se ha repuesto correctamente la contraplaca,

atornillarla correctamente con los tornillos.

Repose backplate previously removed **paying extreme attention** that the plate, through the holes A, matches perfectly with the pins B. The circumstance shown in picture B (crossed with x) should be carefully avoided as it might cause the breakage of the mechanism. Once it is successfully replaced, fix it to the plate with the screws.