

NV3AR

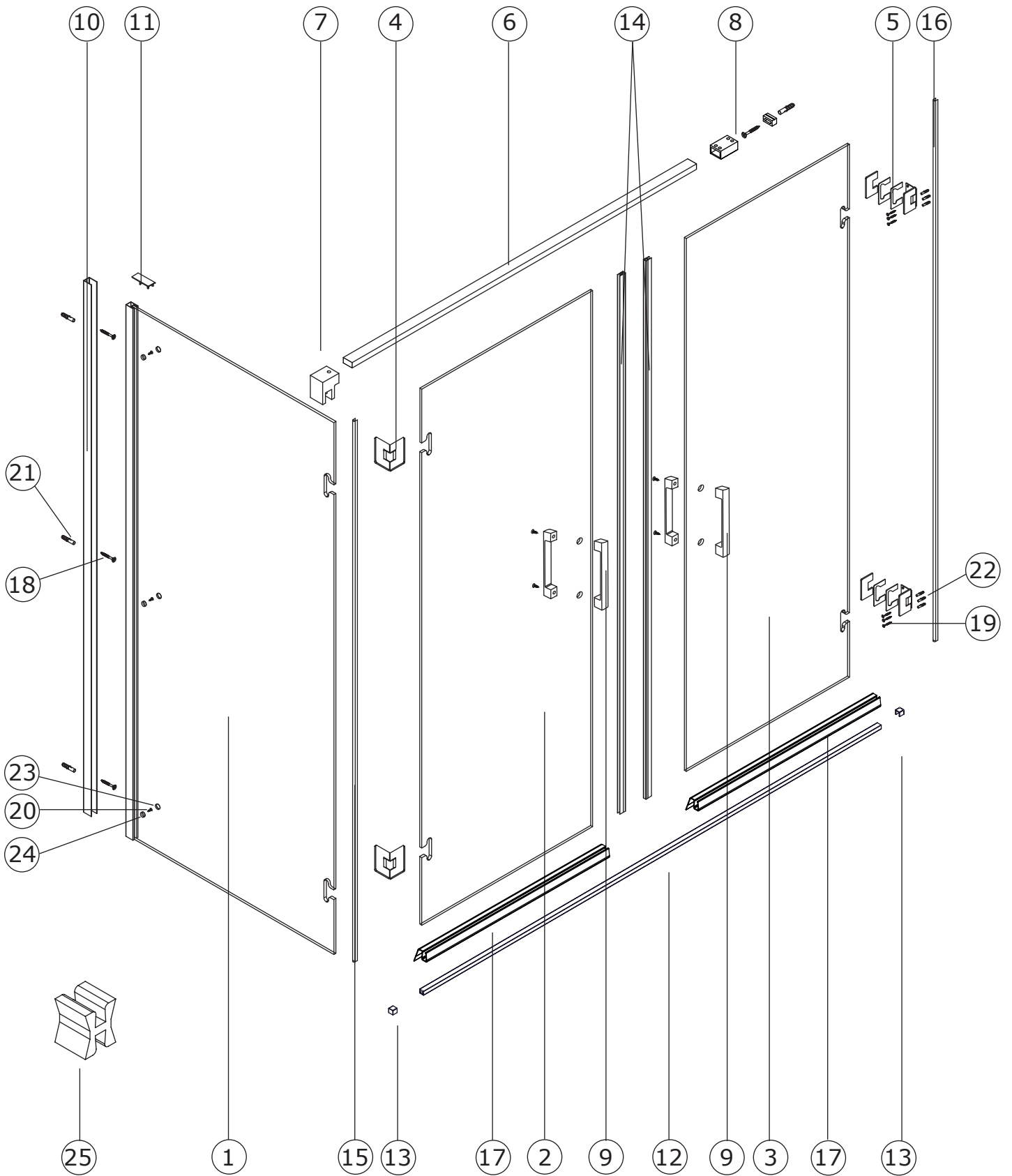

NV3AR

COMPONENTES/COMPONENTS/COMPOSANTS

CODE	DESCRIPTION			UNITS
1	VIDRIO FIJO LATERAL	LATERAL FIXED GLASS	PAROI FIXE LATÉRALE	1
2	VIDRIO MÓVIL IZQUIERDA	LEFT MOBILE GLASS	PAROI MOBILE GAUCHE	1
3	VIDRIO MÓVIL DERECHA	RIGHT MOBILE GLASS	PAROI MOBILE DROITE	1
4	BISAGRA VIDRIO-VIDRIO	GLASS-GLASS HINGE	CHARNIÈRE PAROI-PAROI	2
5	BISAGRA VIDRIO-PARED	GLASS-WALL HINGE	CHARNIÈRE PAROI-MUR	2
6	BARRA DE REFUERZO	REINFORCEMENT BAR	BARRE DE RENFORCEMENT	1
7	SUJECCIÓN LATERAL BARRA	BAR SIDE FASTENING	FIXATION LATÉRALE À LA BARRE	1
8	SUJECCIÓN A PARED BARRA	BAR WALL FASTENING	FIXATION DE LA BARRE AU MUR	1
9	TIRADOR	SHOOTER	TIREUR	2
10	PERFIL A PARED	WALL ATTACHMENT PROFILE	PROFILÉ À LA PAROI	1
11	TAPA PERFIL A PARED	WALL ATTACHMENT PROFILE COVER	EMBOUT PROFILÉ MURAL	1
12	VIERTEAGUAS	RAIN GUARD	REJINGOT	1
13	TAPA VIERTEAGUAS	RAIN GUARD PROFILE COVER	COUVERCLE DU REJINGOT	2
14	JUNTA MAGNÉTICA	MAGNETIC JOINT	JOINT MAGNÉTIQUE	2
15	JUNTA BISAGRA	HINGE JOINT	JOINT DE LA CHARNIÈRE	1
16	JUNTA BISAGRA PARED	WALL HINGE JOINT	JOINT DE LA CHARNIÈRE MUR	1
17	GOMA INFERIOR	LOWER RUBBER	JOINT INFÉRIEUR	2
18	TORNILLOS A PARED	WALL SCREW	VIS MURALE	3
19	TORNILLO INOX. (BISAGRA)	SCREW STAINLESS (HINGE)	VIS INOX. (CHARNIÈRE)	6
20	AUTORROSCANTES	SELF-TAPPING SCREW	VIS AUTO-PERFORANTE	3
21	TACO	WALL PLUG	CHEVILLE	3
22	TACO (BISAGRAS)	WALL PLUG (HINGE)	CHEVILLE (CHARNIÈRE)	6
23	EMBELLECEDORES	FINISH SCREW	ENJOLIVEURS CACHE-VIS	3
24	ARANDELAS	WASHER	RONDELLE	3
25	CALZO	CHOCK	CALE	1
26	PLANTILLA COLOCACIÓN BARRA	TEMPLATE PLACEMENT BAR	POCHOIR POUR PLACEMENT DE LA BARRE	1

HERRAMIENTAS NECESARIAS/TOOLS NEEDED/OUTILS NÉCESSAIRES

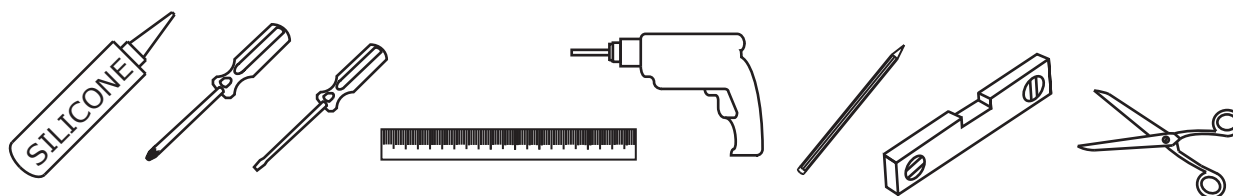

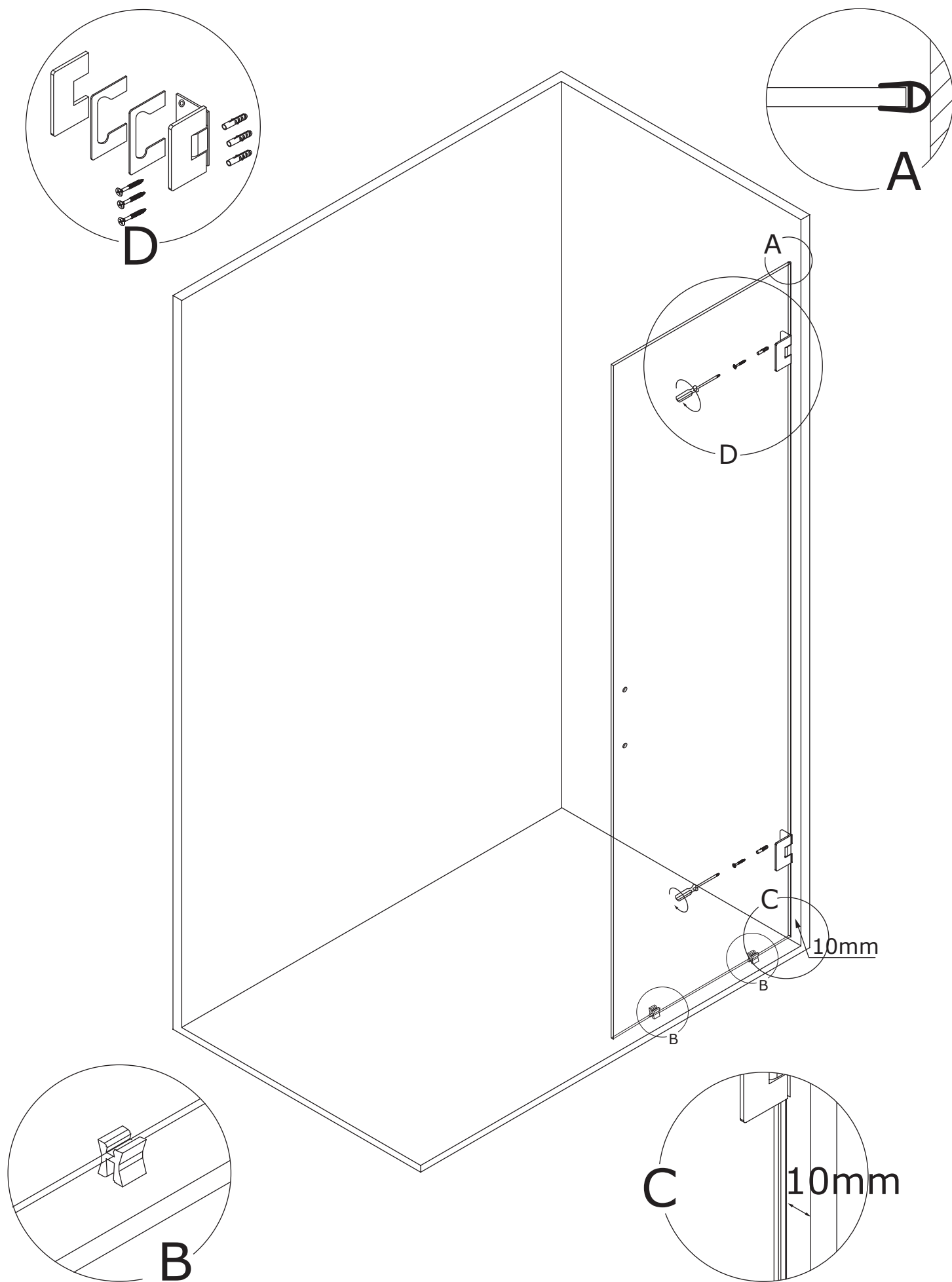

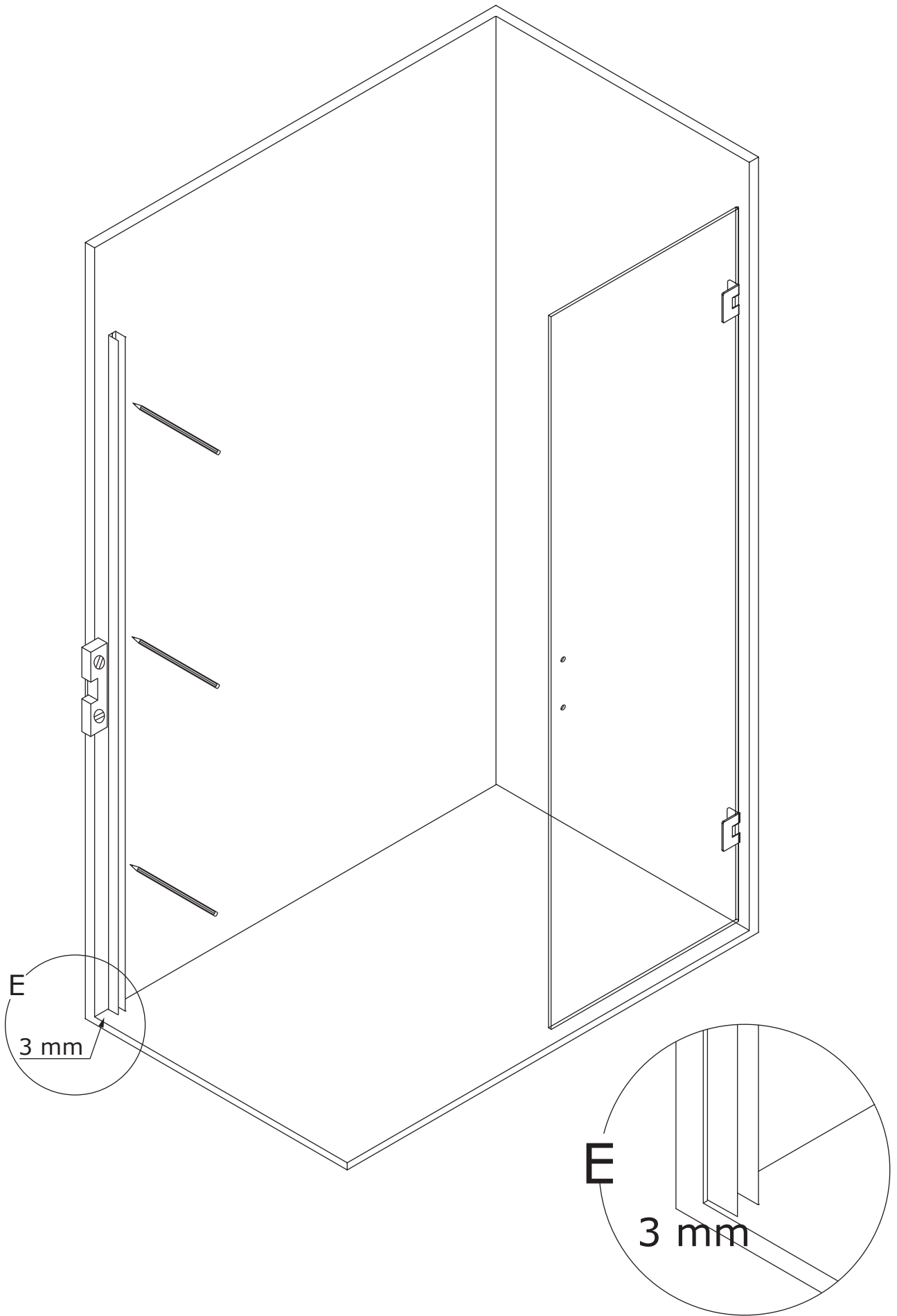

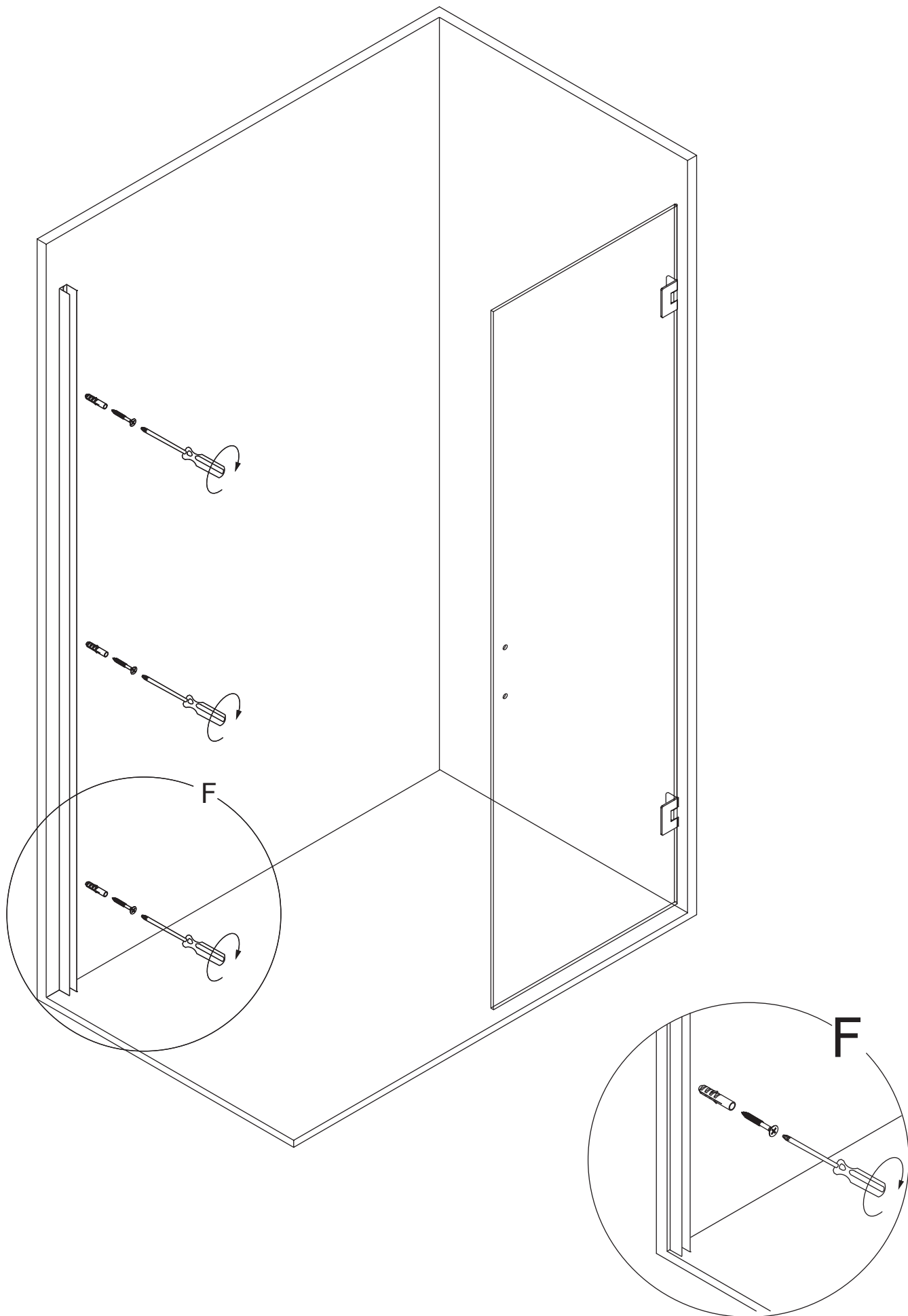

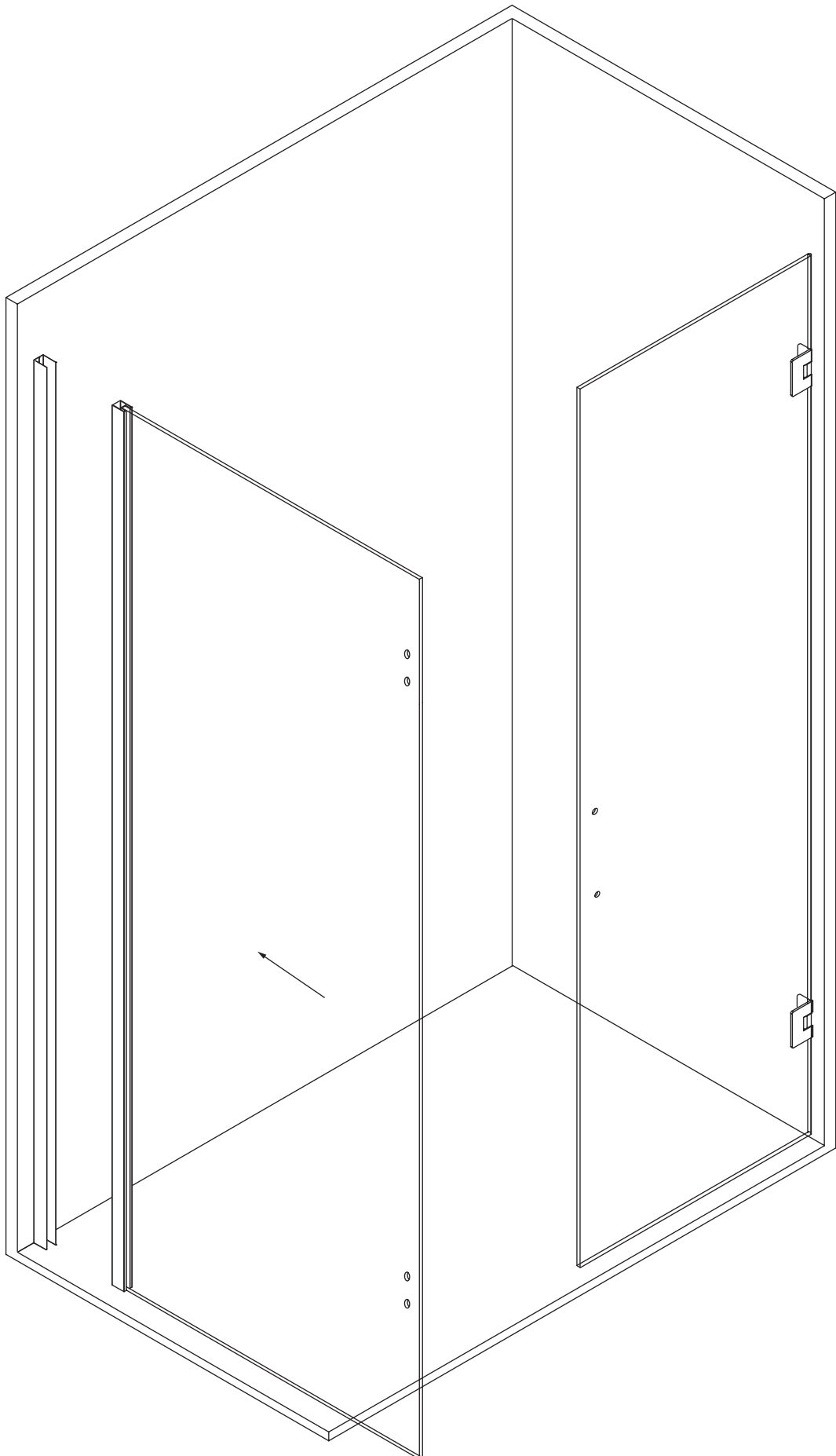

NV3AR

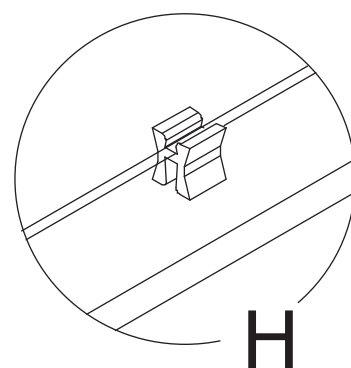
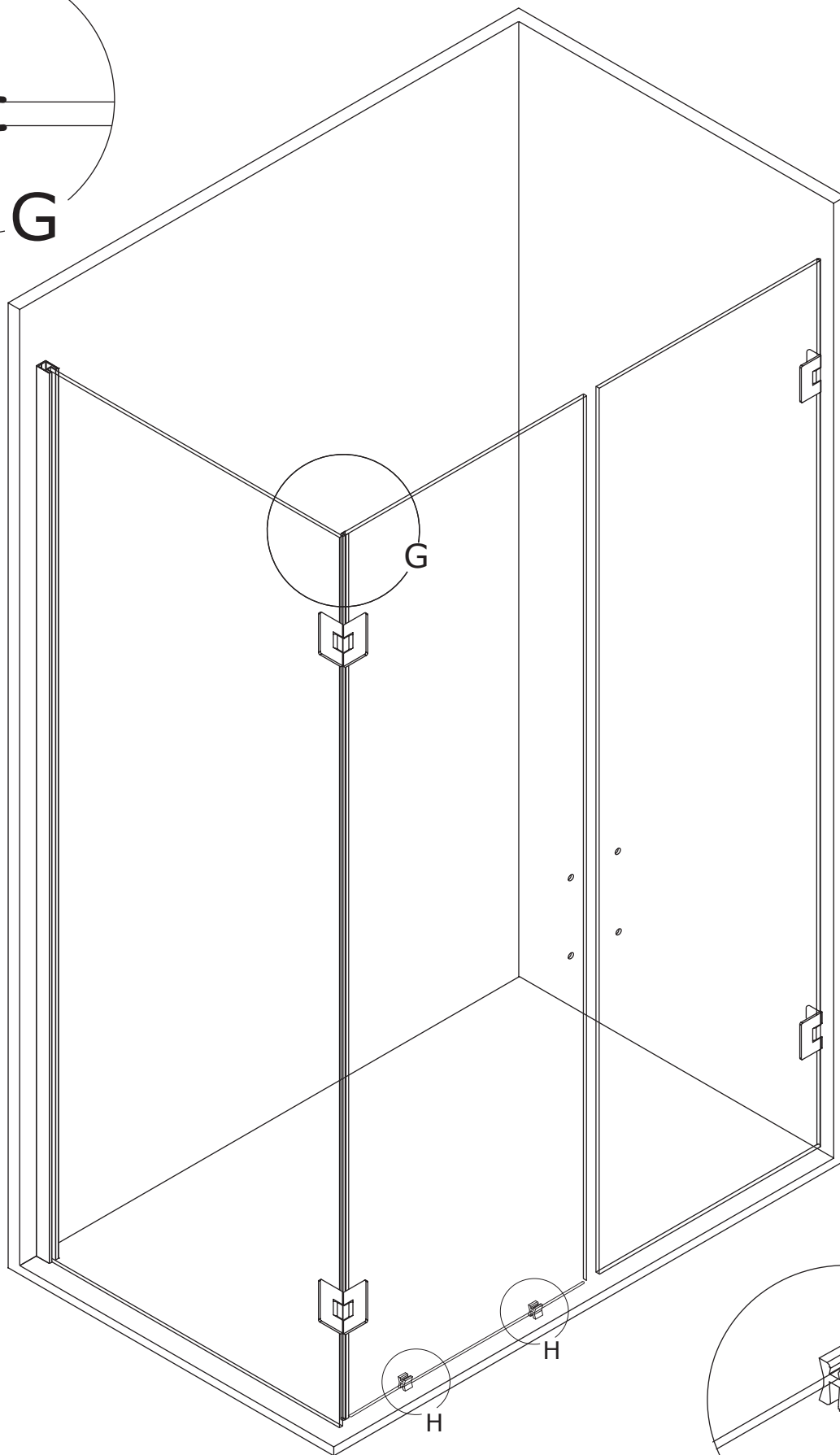
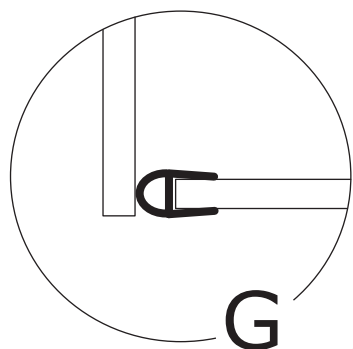

NV3AR

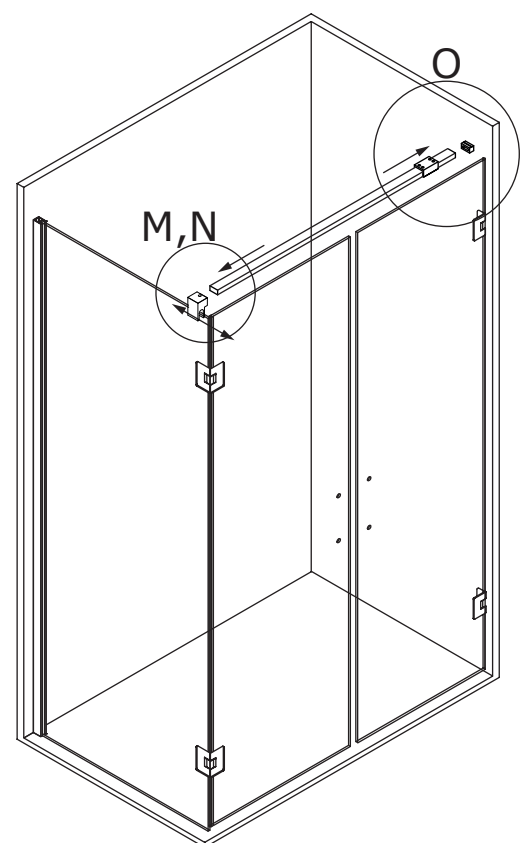
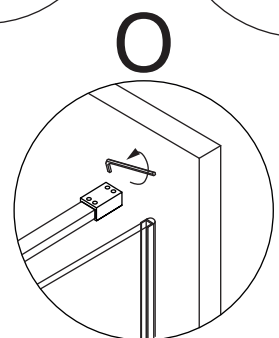
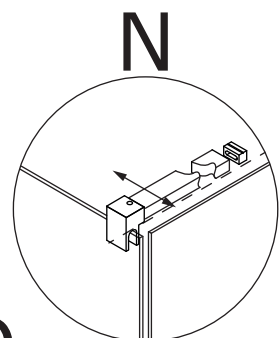
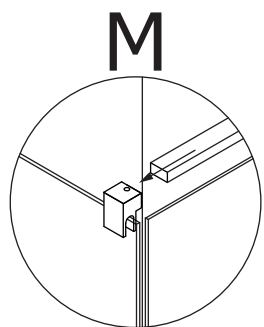
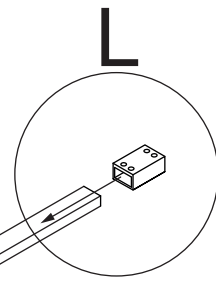
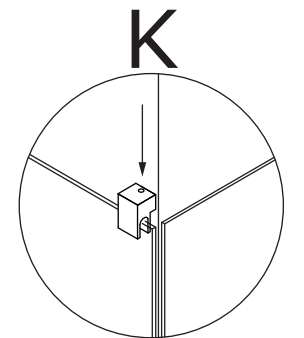
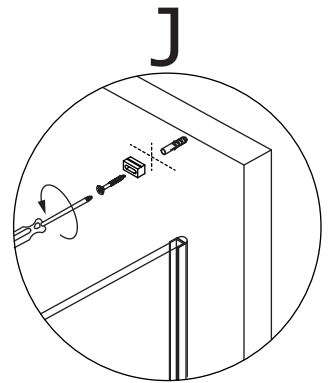
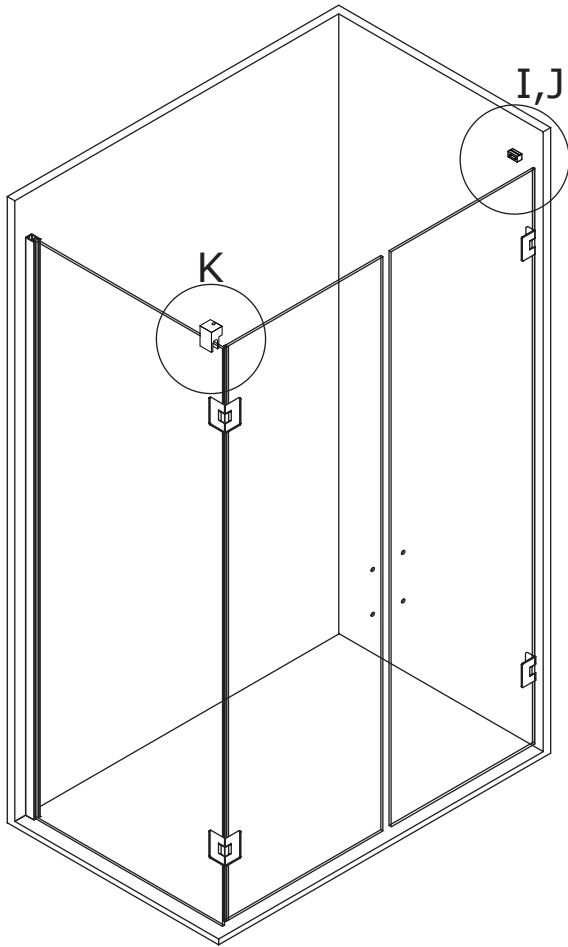

NV3AR

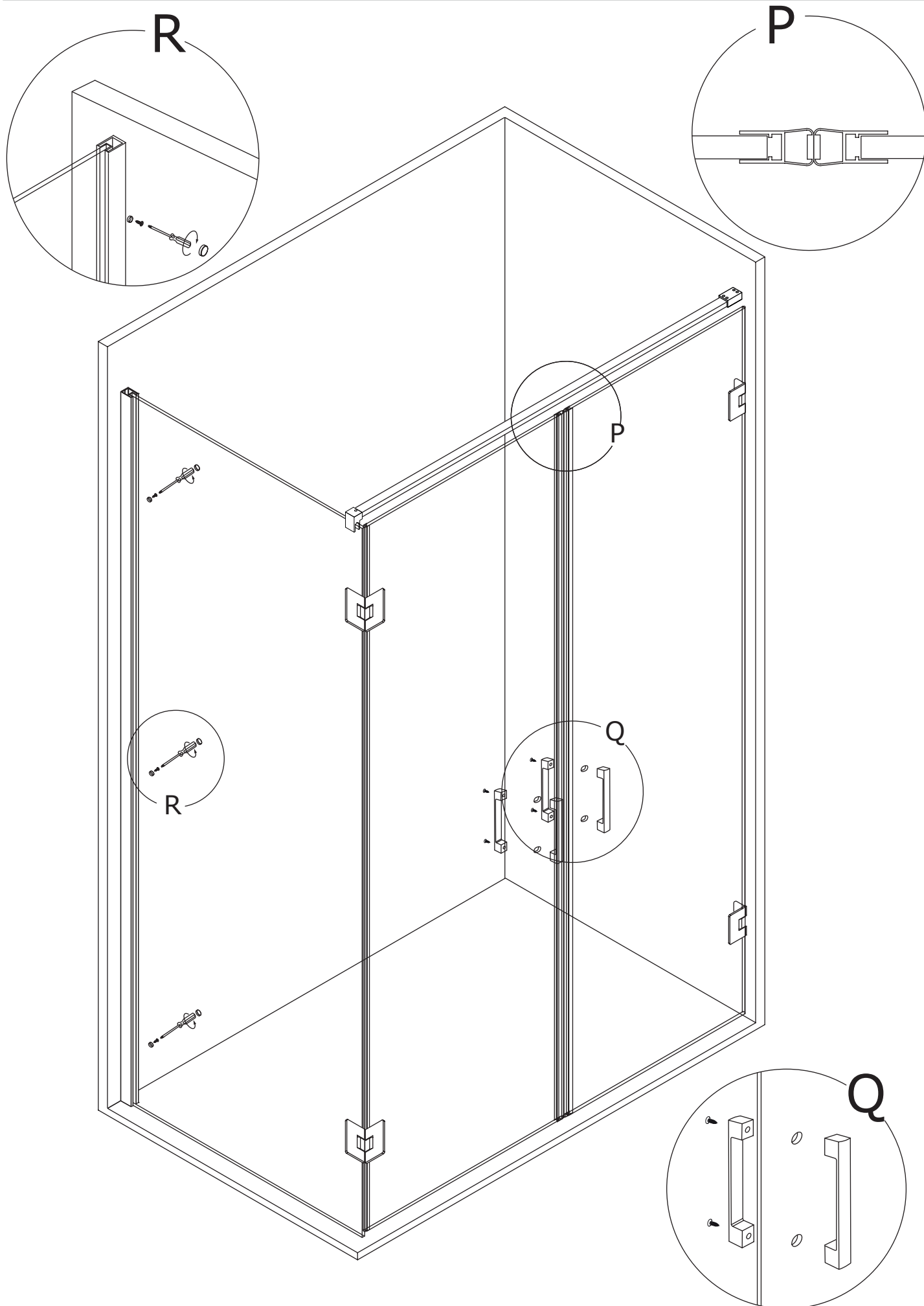

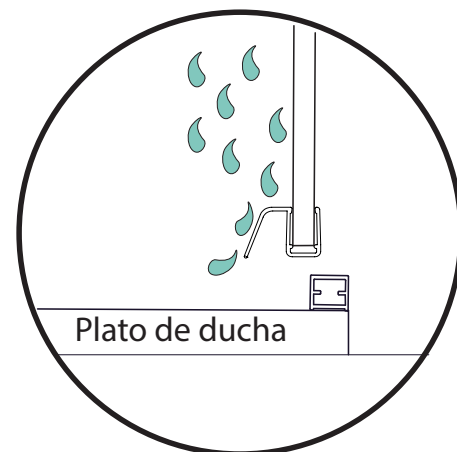
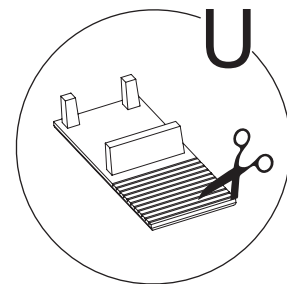
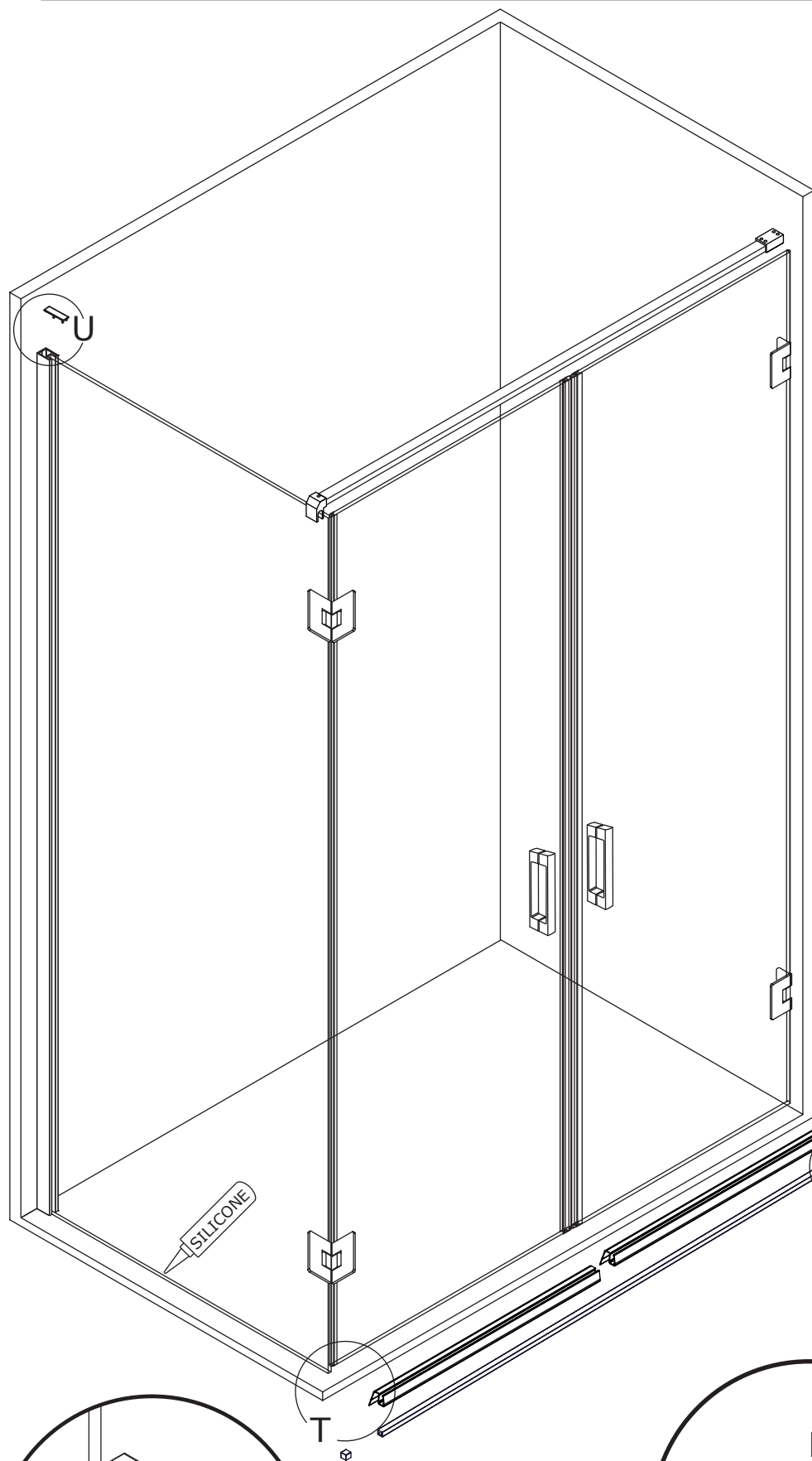

En el caso de que la junta roce demasiado con el vierteaguas, recortar la lengüeta para evitar que se pellizque

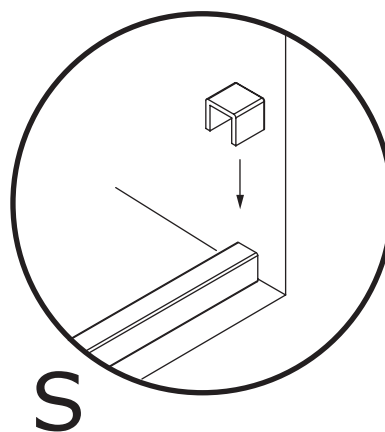
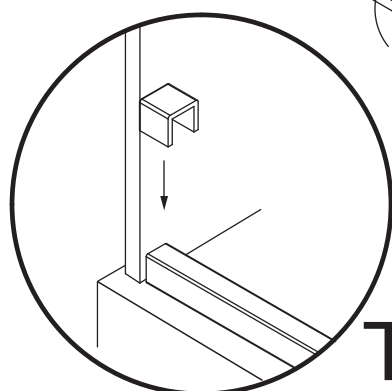
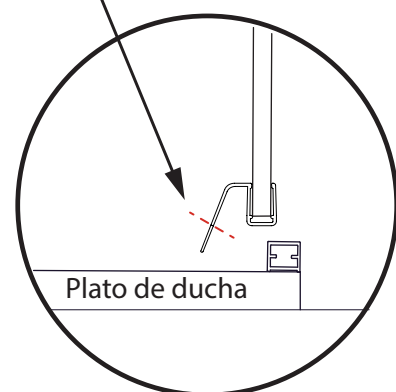
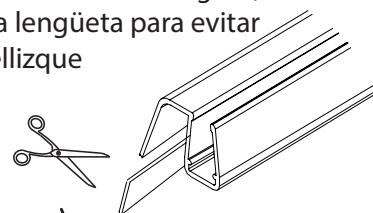

Eva - Eva Pro: E02C61/E02C62/E02C71/E02C72	
Espesor del vidrio Glass thickness	6-8-10mm
Màxima capacidat de pesu Maximum weight capacity	55KG
Anchura màxima de la puertu Maximum door width	840mm

1 Abertura

Destornillar los tornillos de la contraplaca. Después de haber removido la contraplaca, **no efectúen ningún movimiento de rotación de la bisagra.**

Unscrew the backplate screws. After removing the backplate **do not perform any rotation movement** to the hinge.

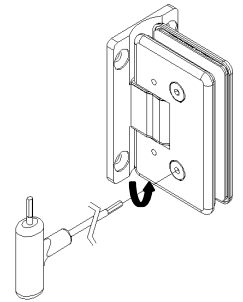

2 Guarniciones

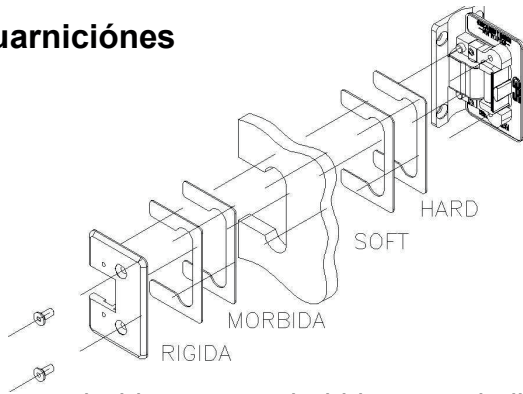

Espesor del vidrio Glass thickness	6mm	8mm	10mm
Guarnición rígida Hard gasket	N°2+2	N°2	N°0
Guarnición blanda Soft gasket	N°2	N°2	N°2

Insertar la bisagra en el vidrio como indicado en el esquema sobrestante, respetando la cantidad y la secuencia de las guarniciones. (Si el espesor del vidrio es inferior del nominal, insertar la guarnición blanda adicional suministrada en la parte externa de la bisagra para asegurar un buen agarre). Se recomienda montar ante todo la bisagra en la puerta y después en la pared

Install the hinge in the glass according to the drawing above. Pay attention to the number and sequence of the gaskets. (In case of glass thickness is less than nominal value, add in the external side, the extra soft gasket supplied to ensure a good grip of the hinge). Advice: first install the hinge on the door then on the

3 Cierre



atornillarla correctamente con los tornillos.

Reponer la contraplaca precedentemente removida.

Ponerse un cuidado especial de que la placa, a través de los agujeros A sean perfectamente acoplados con los pernos B. La situación el la imagen cruzada con X nunca debe presentarse, ya que eso podría implicar la possible ruptura del mecanismo. Una vez que se ha repuesto correctamente la contra placa,

Repose backplate previously removed **paying extreme attention** that the plate, through the holes A, matches perfectly with the pins B. The circumstance shown in picture B (crossed with x) should be carefully avoided as it might cause the breakage of the mechanism. Once it is successfully replaced, fix it to the plate with the screws.